

# Powder design for UV-attenuating agent with high transparency for visible light

T. IWASAKI\*, M. SATOH, T. MASUDA

Department of Chemical Engineering, College of Engineering, Osaka Prefecture University,  
1-1 Gakuen-cho, Sakai, Osaka 599-8531, Japan  
E-mail: iwasaki@chemeng.osakafu-u.ac.jp

T. FUJITA

Sakai Chemical Industry Co., Ltd., 5-1 Ebisujima-cho, Sakai, Osaka 590-0985, Japan

To design high-performance ultraviolet (UV)-attenuating agent for dispersion type of functional paints and/or cosmetic powders, nano-meter size of zinc oxide (ZnO) powder was immobilized onto the surface of 4  $\mu\text{m}$  square size of crystalline sheet (H-ilerite: synthetic polysilicic acid (PSA)). A high-speed elliptical-rotor-type powder mixer (HEM) was applied for exfoliating in a sheet one by one from the PSA agglomerates without breakage of the original shape and for arranging the ZnO in the mono-particle layer on the sheet during dispersing the self-coagulative ultra-fine ZnO. The critical operating conditions of the HEM were determined by an observation of the morphological change of PSA. Optical characteristics of the compounded powder (ZnO-PSA) were evaluated in the form of suspension dispersed into polymer medium. The UV-attenuating effect was confirmed in the UVA region (320–400 nm) and the heat treatment after immobilization was one of the effective methods to get higher transparency for visible light. © 2000 Kluwer Academic Publishers

## 1. Introduction

Fine particles of oxide of metal (e.g. titanium, zinc, zirconium, iron, etc.) are extensively used as agents to attenuate (absorb and/or scatter) the ultraviolet (UV) radiation (wavelength 290–400 nm). The zinc oxide (ZnO) powder attenuates more effectively the UV radiation in not only the UVB (290–320 nm) but also the UVA (320–400 nm) region and has the lower value (about 1.9) of refractive index than other metal oxides which have been used as the agent [1–5].

Various UV-attenuating formulations in which the metal oxide particles are incorporated into liquid or polymer media are manufactured, such as sunscreens, paints, anti-UV additives for plastics and skin care cosmetics, etc. It is required that such formulations have the multiformity of coloring; the particle-dispersed suspension before being colored is desired to have a high transparency for visible light. To increase the transparency and to attenuate the UV radiation effectively with lower content of metal oxide particles, nano-meter size of primary single particles must be dispersed homogeneously into the medium [1–3]. However, the dispersion of ultra-fine particles is very difficult without any reagent because of the interactive force among the particles [2, 5].

In this study, to stabilize the homogeneous dispersion of particles in the suspension and to give high transparency to the suspension, the ZnO particles are

immobilized (compounded) mechanically onto the surface of crystalline sheet powder, arranging at the state of random packing in the mono-particle layer. For the compounded powder dispersed in the transparent polymer medium, the UV-attenuating performance and the transparency for visible light are evaluated on the basis of spectrophotometry.

## 2. Experimental

### 2.1. Materials

Fig. 1 shows the scanning electron micrograph of ultra-fine ZnO powder with the average diameter of 20 nm (FINEX-50, Sakai Chemical Industry, true density 5.6  $\text{g cm}^{-3}$ ). The ZnO particles are formed agglomerates of about 1–5  $\mu\text{m}$  in diameter due to the cohesive force among particles. Crystalline sodium polysilicate hydrate ( $\text{Na}_2\text{Si}_8\text{O}_{17}\cdot 10\text{H}_2\text{O}$ ), so-called “ilerite” [6–10], was synthesized by the hydrothermal crystallization at 380 K for 280 hours in the system  $\text{Na}_2\text{O}-\text{SiO}_2-\text{H}_2\text{O}$ . In this study, H-ilerite [8, 10] (polysilicic acid (PSA), true density 2.4  $\text{g cm}^{-3}$ ) was chosen, considering the application of materials to the human skins. The PSA powder was prepared by a series of wet-base process, i.e. decationizing the polysilicate with a dilute hydrochloric acid, separating from the mother liquid, washing at room temperature, and drying at 353 K. Therefore, the PSA powder obtained by this process formed the

\* Author to whom all correspondence should be addressed.

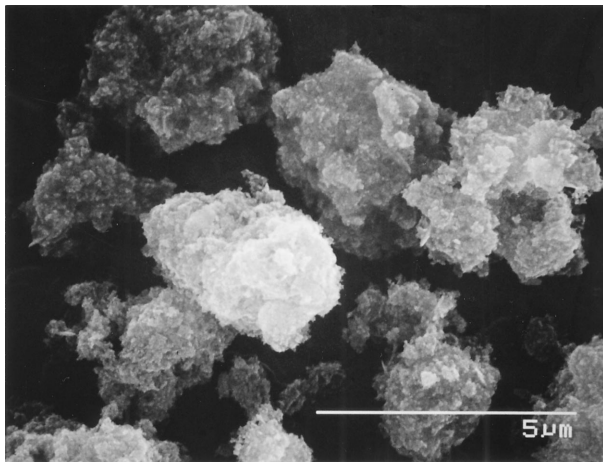

Figure 1 Scanning electron micrograph of ZnO powder.

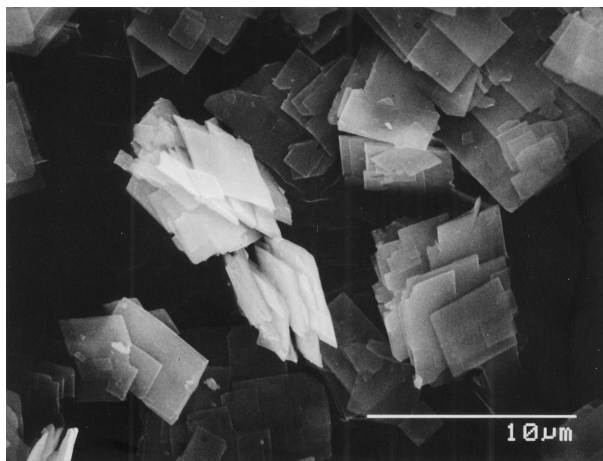

Figure 2 Scanning electron micrograph of polysilicic acid (PSA) powder (H-ilerite).

accumulating agglomerates as shown in Fig. 2. The size of the square sheet was about  $4 \mu\text{m} \times 4 \mu\text{m} \times 0.2 \mu\text{m}$  in dimensions.

## 2.2. Equipment

The schema of the compounding machine (the high-speed elliptical-rotor-type powder mixer: HEM) [11, 12] used in this study is shown in Fig. 3. This equipment has the features of both vessel-rotating mixers and

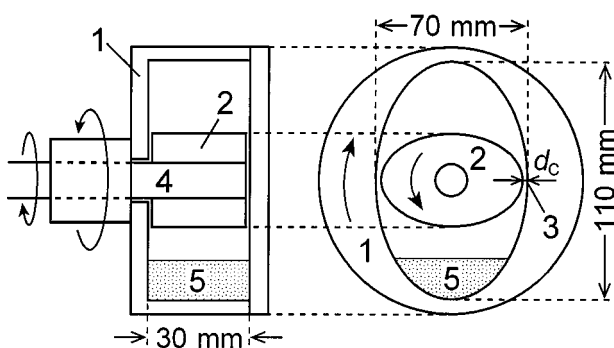

Figure 3 Schematic illustration of the high-speed elliptical-rotor-type powder mixer (HEM). 1, Vessel; 2, rotor; 3, minimum clearance; 4, shaft; 5, powder.

high-speed-stirring mixers with strong shear force. The elliptical vessel (barrel) rotates at a speed less than the critical rotary speed, and the elliptical rotor setting inside the vessel rotates co-axially at a fairly high speed in the opposite direction to the rotation of vessel. The major axis length of the rotor is set to be shorter than the minor axis length of the vessel so that a narrow clearance appears periodically between the vessel wall and the tip of the rotor. A strong shear force acts on the powders repeatedly at this clearance region.

To control the intensity of dispersing and/or compounding stress on the powders, proper amount of zirconia bead (0.3 mm in diameter) are added in the mixer vessel. The mixture ratio ( $V_B/V_P$ ) of beads and PSA powder is varied to investigate the effects of the bead additive on the dispersion, where  $V_B$  and  $V_P$  represent the bulk volumes of the beads and PSA powder, respectively. In the case of beads additive, the distance of minimum clearance ( $d_C$ ) was set at 2.0 mm; on the other hand,  $d_C = 0.5$  mm in the treatment without the beads. In all experiments, the total volume of beads and PSA powder was 20% of the effective volume ( $V_V$ ) of vessel, i.e.  $(V_B + V_P)/V_V = 0.2$ , and the rotary speeds of vessel and rotor were kept at 35 and  $2500 \text{ min}^{-1}$ , respectively.

## 2.3. Method

Fig. 4 shows the flow sheet of experimental procedure. To determine the optimum operating condition in which no breakage of the original shape of PSA by the beads occurred, the exfoliation treatment was carried out under the condition of  $V_B/V_P$  in the range of 0 to 0.5 ( $V_B/V_P = 0$  means that no bead was added). The exfoliation stage was evaluated by measuring of specific surface area for the PSA powder with an automatic surface area analyzer (Beta Scientific, Model 4200). After the exfoliation treatment, 8.5 wt % of the ZnO powder was introduced into the HEM removed the beads and set at  $d_C = 0.5$  mm of the clearance. The dispersing and compounding (immobilizing) operation of ZnO and PSA mixture was carried out without the beads for desired time. The compounding state of the mixture throughout the process was assessed by a morphological observation (scanning electron microscope) and by an ultrasonic-separation test in the water bath (Nihonseiki, US-150T). To complete the immobilization and to increase the transparency, the compounded powder (ZnO-PSA) was heated (sintered) at 773 K for 2 hours in an atmosphere of air in the sintering furnace. The content of ZnO in the ZnO-PSA before and after the heat treatment was measured by means of inductively coupled plasma (ICP) spectrometry.

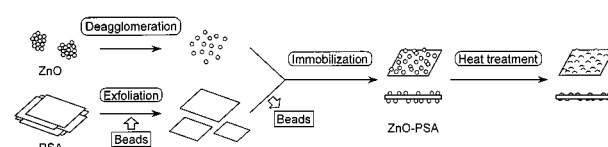

Figure 4 Manufacturing process of the compounded powder (ZnO-PSA).

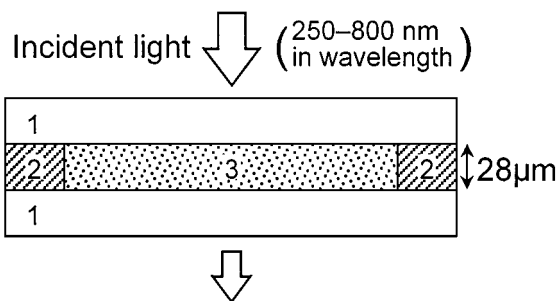

Figure 5 Schematic illustration of the test cell. 1, Quartz glass plate; 2, polypropylene film (spacer); 3, sample.

For evaluation of the optical characteristics, the ZnO-PSA powder was mixed with the vaseline medium (following the Japanese pharmacopeia, Tatsumi Pharmaceutical) using a laboratory muller (Toyoseiki) at room temperature. The amount of ZnO-PSA content in the mixed paste was 20 wt %, i.e. the net concentration of ZnO in the paste was 1.7 wt %. The paste was set between a pair of quartz glass plates, of which clearance was  $28\ \mu\text{m}$ , as illustrated in Fig. 5. The transmittance in the range of wavelength of 250 to 800 nm was measured with a spectrophotometer (JASCO, Ubest V-550DS).

### 3. Results and discussion

#### 3.1. Exfoliation of PSA agglomerates

Fig. 6 shows the variation in the specific surface area ( $S_p$ ) of PSA powder with the treatment time. When no zirconia beads were added ( $\square$ ), the PSA agglomerates were hardly exfoliated and  $S_p$  was constant (about  $8\ \text{m}^2\ \text{g}^{-1}$ ) in spite of applying the relatively high stress on the PSA at the narrower clearance region. On the contrary, in the case of the beads additive ( $V_B/V_P = 0.5$ ,  $\Delta$ ),  $S_p$  increased linearly with the progress in the treatment time. Under this operating condition, the exfoliation of PSA and the breakage of crystalline sheet occurred simultaneously as shown in Fig. 7a. It made clear that the surplus shearing and com-

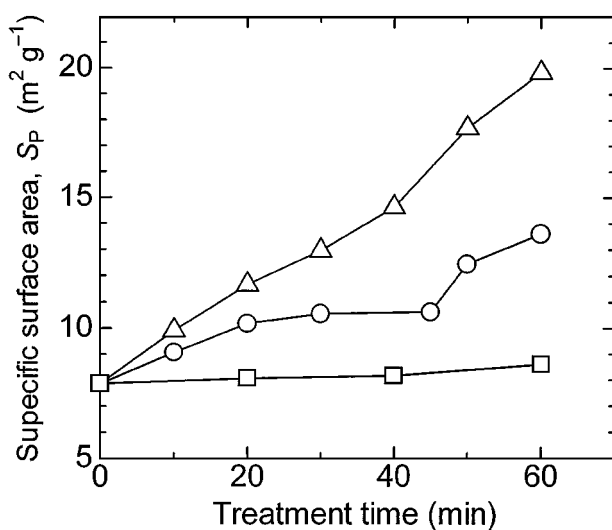
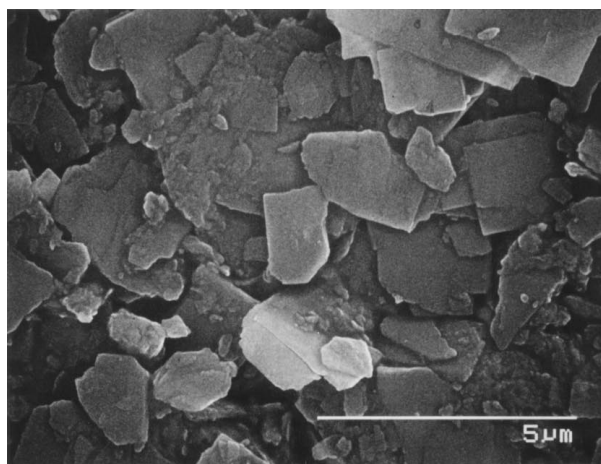
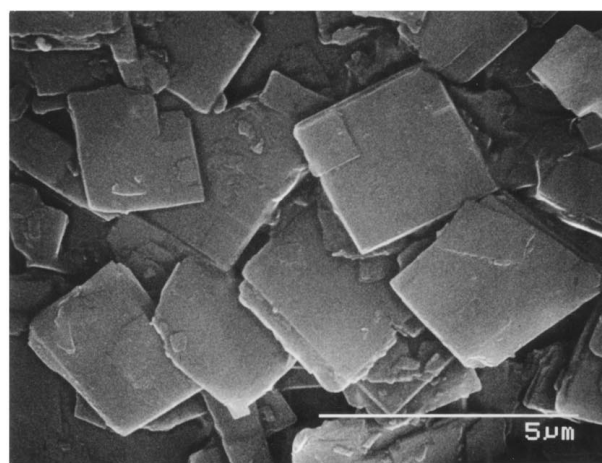

Figure 6 Variation in the specific surface area ( $S_p$ ) of PSA with the treatment time. ( $\Delta$ )  $V_B/V_P = 0.5$ ,  $d_C = 2.0\ \text{mm}$ ; ( $\circ$ )  $V_B/V_P = 0.2$ ,  $d_C = 2.0\ \text{mm}$ ; ( $\square$ )  $V_B/V_P = 0$  (without the beads),  $d_C = 0.5\ \text{mm}$ .



(a)



(b)

Figure 7 Scanning electron micrographs of the PSA after the exfoliation treatment for 30 min. (a)  $V_B/V_P = 0.5$ ; (b)  $V_B/V_P = 0.2$ .

pressing stress by the beads acts on the soft crystalline material under the condition of high  $V_B/V_P$ . Therefore, the amount of beads was reduced to the ratio of  $V_B/V_P = 0.2$  ( $\circ$ ). After  $S_p$  increased at the initial stage of operation due to the exfoliation of PSA,  $S_p$  was kept at constant (about  $10\ \text{m}^2\ \text{g}^{-1}$ ) from 20 to 45 min. It was observed that the PSA within the time period was exfoliated in each sheet maintaining its original shape as shown in Fig. 7b. The continuance of the operation under this condition caused the breakage of the sheets, and  $S_p$  increased with the time. The results shows that there is the range of the optimal operating condition in which the proper stress acts on the PSA and that the volume ratio of beads and powder,  $V_B/V_P$ , is one of the effective controllable parameter to get desired size of crystalline sheet in high yield.

#### 3.2. Immobilization of ZnO onto PSA

From the initial stage of the dispersing and compounding operation, the agglomerates of ZnO were deagglomerated gradually with the progress in the operating time. Simultaneously, the number of ZnO particle adhered on the surface of PSA increased. Fig. 8 shows the scanning electron micrograph of the compounded powder (ZnO-PSA) obtained by the operation for 60 min.

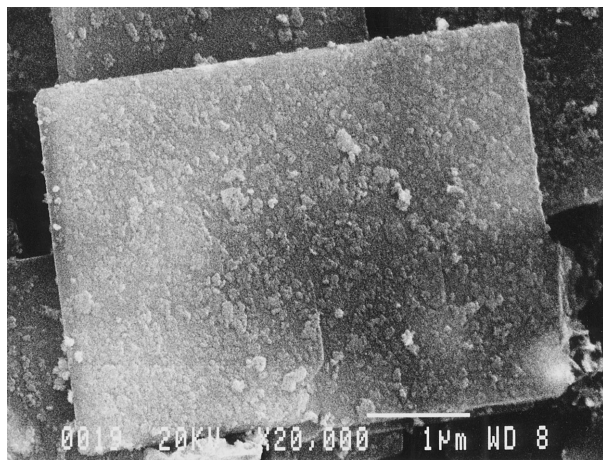

Figure 8 Scanning electron micrograph of the ZnO-PSA obtained by the operation for 60 min.

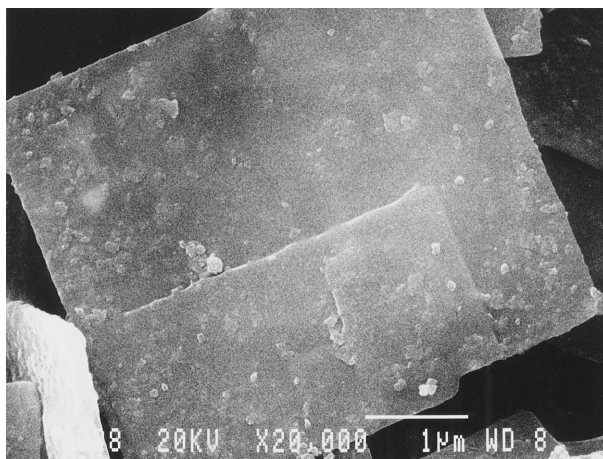

Figure 9 Scanning electron micrograph of the ZnO-PSA after the heat treatment.

The ZnO particles were adhered on the PSA arranging at random. The shape of crystalline sheet of PSA was maintained throughout the operation. The compounding state did not progress anymore over 60 min. No extrication of ZnO particles from the PSA was observed after 5 min soaking in the ultrasonic water bath. As shown in Fig. 9, the fusion of ZnO particles occurred by the heat treatment whereas the PSA did not change in appearance. It was confirmed that the content of ZnO in the ZnO-PSA had been constant throughout the heat treatment. This means that the ZnO were immobilized completely on the PSA.

### 3.3. Transmittance of suspension of ZnO-PSA

The measurement result of the transmittance is shown in Fig. 10 together with those for the vaseline (i.e. the blank), the paste mixed with the PSA of 18.3 wt %, and that with the ZnO of 1.7 wt %. The PSA powder (the curve 2 in Fig. 10) hardly attenuates the UV radiation in the range of 300 to 400 nm whereas the transparency in the visible light region (400–800 nm) was relatively high. The ZnO-incorporated paste (the curve 3) attenuated considerably the UV radiation in spite of form-

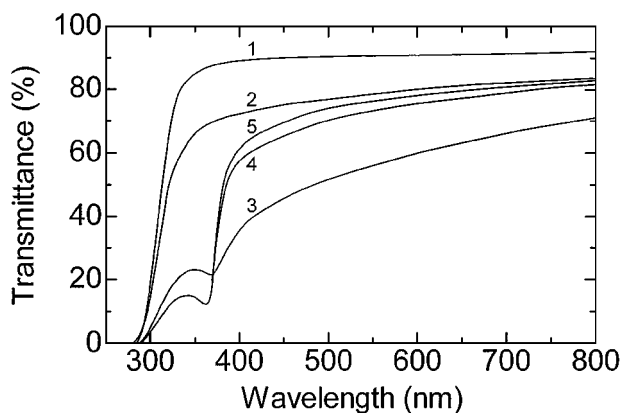

Figure 10 Transmittance of mixture with vaseline. 1, Blank (only vaseline); 2, PSA; 3, ZnO; 4, the ZnO-PSA; 5, the heat-treated ZnO-PSA.

ing the agglomerates of ZnO in the vaseline. However, the transparency was low because of the scattering of visible light by the agglomerates. On the contrary, the ZnO-PSA-incorporated paste (the curve 4) attenuated effectively the UV radiation (especially in the UVA region) and the transparency increased. Furthermore, by the heat treatment, the transmittance in the visible light region approached that of the PSA whereas the UV-attenuating effect was maintained, as indicated by the curve 5. Thus, by the use of the heat-treated ZnO-PSA powder, the transmittance in the UV region decreased about 10% (maximum at 360 nm) and that in the visible light region increased about 18% on the average in comparison with the case of using single component, ZnO powder.

## 4. Conclusions

The compounded powder of ultra-fine ZnO and crystalline PSA was manufactured by the simple method with the HEM. The ZnO particles were immobilized onto the surface of PSA sheet without any reagent. The optimum operating condition of the HEM in a series of manufacturing process was determined as follows: (i) the exfoliation treatment of PSA agglomerates,  $V_B/V_P = 0.2$  and  $d_C = 2.0$  mm for 30 min, and (ii) the immobilization of ZnO particles,  $V_B/V_P = 0$  and  $d_C = 0.5$  mm for 60 min. The heat treatment of compounded powder was effective for the improvement on the transparency.

The stabilization of the homogeneous dispersion of ultra-fine ZnO particles was achieved by dispersing the compounded powder into the medium. The suspension had the high transparency and attenuated the UV radiation in the UVA region with lower content (1.7 wt %) of ZnO.

## References

1. M. A. MITCHNICK, *Cosmet. Toiletries* **107** (1992) 111.
2. D. FAIRHURST and M. A. MITCHNICK, in "Sunscreens; Development, Evaluation, and Regulatory Aspects," 2nd ed., edited by N. J. Lowe, N. A. Shaath and M. A. Pathak (Marcel Dekker, New York, 1997) p. 313.
3. M. W. ANDERSON, J. P. HEWITT and S. R. SPRUCE, *ibid.* p. 353.

4. M. A. MITCHNICK, D. FAIRHURST and S. R. PINNELL, *J. Am. Acad. Dermatol.* **40** (1999) 85.
5. M. TÜRKOĞLU and S. YENER, *Int. J. Cosmet. Sci.* **19** (1997) 193.
6. R. K. ILER, *J. Colloid Sci.* **19** (1964) 648.
7. G. BORBÉLY, H. K. BEYER, H. G. KARGE, W. SCHWIEGER, A. BRANDT and K.-H. BERGK, *Clays and Clay Minerals* **39** (1991) 490.
8. K. KOSUGE and A. TSUNASHIMA, *J. Chem. Soc., Chem. Commun.* **1995** (1995) 2427.
9. H. BINDER, B. KOHLSTRUNK, U. BRENN, W. SCHWIEGER and G. KLOSE, *Colloid Polym. Sci.* **276** (1998) 1098.
10. Y. HUANG, Z. JIANG and W. SCHWIEGER, *Chem. Mater.* **11** (1999) 1210.
11. M. SATOH, T. YOSHIDA, K. MIYANAMI and Y. OKUDAIRA, *J. Soc. Powder Technol. Jpn* **31** (1994) 789.
12. T. IWASAKI, T. KOGA and M. SATOH, *J. Jpn Soc. Powder and Powder Met.* **45** (1998) 812.

*Received 30 August 1999  
and accepted 22 February 2000*